

UWB Emission Measurements

Jun-ichi TAKADA
Tokyo Institute of Technology

University of Oulu, September 23, 2005

Outline

1. Background
2. Impact to existing systems and regulatory issues
3. Spectral emission mask
4. UWB parameters
5. Frequency domain vs time domain measurements
6. Measurement conditions
7. Frequency domain measurements
8. Time domain measurements

Outline

1. Background

2. Impact to existing systems and regulatory issues
3. Spectral emission mask
4. UWB parameters
5. Frequency domain vs time domain measurements
6. Measurement conditions
7. Frequency domain measurements
8. Time domain measurements

Focus

- UWB devices may cause the interference to other existing systems.



- The emissions from UWB devices shall be regulated.

ITU

- International Telecommunication Union
- Established in 1932 as a merger of International Telegraph Union (1865) and International Radio Consultative Committee (CCIR, 1906)
- Oldest UN organization
- Coordination of the international rules and standards for telecommunications
- Headquarter in Geneva, Switzerland

ITU

- Three sectors
 - Telecommunications (ITU-T)
 - Radiocommunications (ITU-R)
 - Development (ITU-D)

ITU-R

- Radiocommunication sector
- Radio Regulations (RR)
 - fundamental law of ITU-R
 - World Radio Conference (WRC)
 - Every 3 years for RR revision
 - Two consequent WRCs
one to approve as a topic, another to approve the revision.

Standardization activity in ITU-R

- SG (study group) 1
Spectrum administration
- TG (task group) 1/8
Compatibility between ultra-wideband devices (UWB) and radiocommunication services

Current status of UWB in ITU-R

Cumbersome system in regulation

- UWB does not belong to any radiocommunication services.
- No frequency is assigned for UWB.



- Impact study to existing radiocommunication services in TG 1/8

ITU-R TG 1/8 meeting

- 1) January 21-24, 2003 in Geneva
- 2) October 27-31, 2003 in Geneva
- 3) June 9-18, 2004 in Boston
- 4) November 3-12, 2004 in Geneva
- 5) May 18-27, 2005 in San Diego
- 6) October 12-20, 2005 in Geneva (final)

This lecture is based on the results of 5th meeting.

Structure of ITU-R TG 1/8

Four working groups (WGs)

- WG1: UWB characteristics
- WG2: impact to existing services
- WG3: frequency management framework
- WG4: measurement techniques
 - Each WG drafts the new recommendation.

Flow of the approval of new recommendation

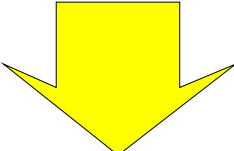
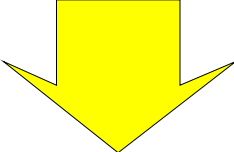
- TG 1/8
 - PDNR (preliminary draft new recommendation)
- 
- SG1
 - DNR (draft new recommendation)
- 
- Vote of member countries by post
 - NR (new recommendation)

Outline

1. Background

2. Impact to existing systems and regulatory issues

3. Spectral emission mask

4. UWB parameters

5. Frequency domain vs time domain measurements

6. Measurement conditions

7. Frequency domain measurements

8. Time domain measurements

Impact of UWB on radiocommunication services

- Originally called “Compatibility”
 - UWB does not belong to any radiocommunication services.
 - Not necessary to be compatible
- Study of the impact to every service within the frequency that UWB systems use.
- WG 2 in charge

Services under study (1)

- Mobile service (SG 8)
 - Land mobile services except IMT-2000
 - Maritime mobile service
 - Aeronautical service (ANRS)
 - IMT-2000 and systems beyond IMT-2000
 - Wireless access systems including RLANs
 - Amateur and amateur-satellite service
 - Meteorological radar

Services under study (2)

- Fixed service (SG 9)
- Fixed-satellite service (SG 4)
- Mobile-satellite services and the radionavigation satellite service (SG8)
 - Mobile-satellite service (MSS)
 - Radionavigation satellite service (RNSS)

Services under study (3)

- Broadcasting service (SG 6)
 - Terrestrial broadcasting
 - Satellite broadcasting
 - Science services (SG 7)
 - Earth exploration-satellite service (EESS)
 - Radio astronomy service (RAS)
- <passive services; most difficult to protect>

Two methodologies for impact study

- Impact of a single UWB device
 - Applicable to mobile terminals etc.
- Impact of an aggregation of UWB devices
 - Applicable to satellite uplink etc.

Impact of a single UWB device

- $EIRP_{MAX} = I_{MAX} - BWCF - G_R(\theta) + L_P + L_R$

$EIRP_{MAX}$ = maximum permitted e.i.r.p. of interfering device,
in dBm/MHz

I_{MAX} = maximum permissible interference level at receiver
input, normalised in dBm/MHz

$BWCF$ = bandwidth correction factor to correct for power of
UWB signal in victim receiver IF bandwidth

$G_R(\theta)$ = victim receiver's antenna gain, in dBi

L_P = propagation loss between Tx and Rx antennas, in dB

L_R = loss between the receiver antenna and receiver input, in
dB

Maximum permissible interference level at receiver

- $I/N = -20$ dB : definition of RR
<legacy of analog systems>
- Some services use more realistic value.
<As victim people evaluate the value, it tends to be pessimistic to UWB.>

Summary of impact study

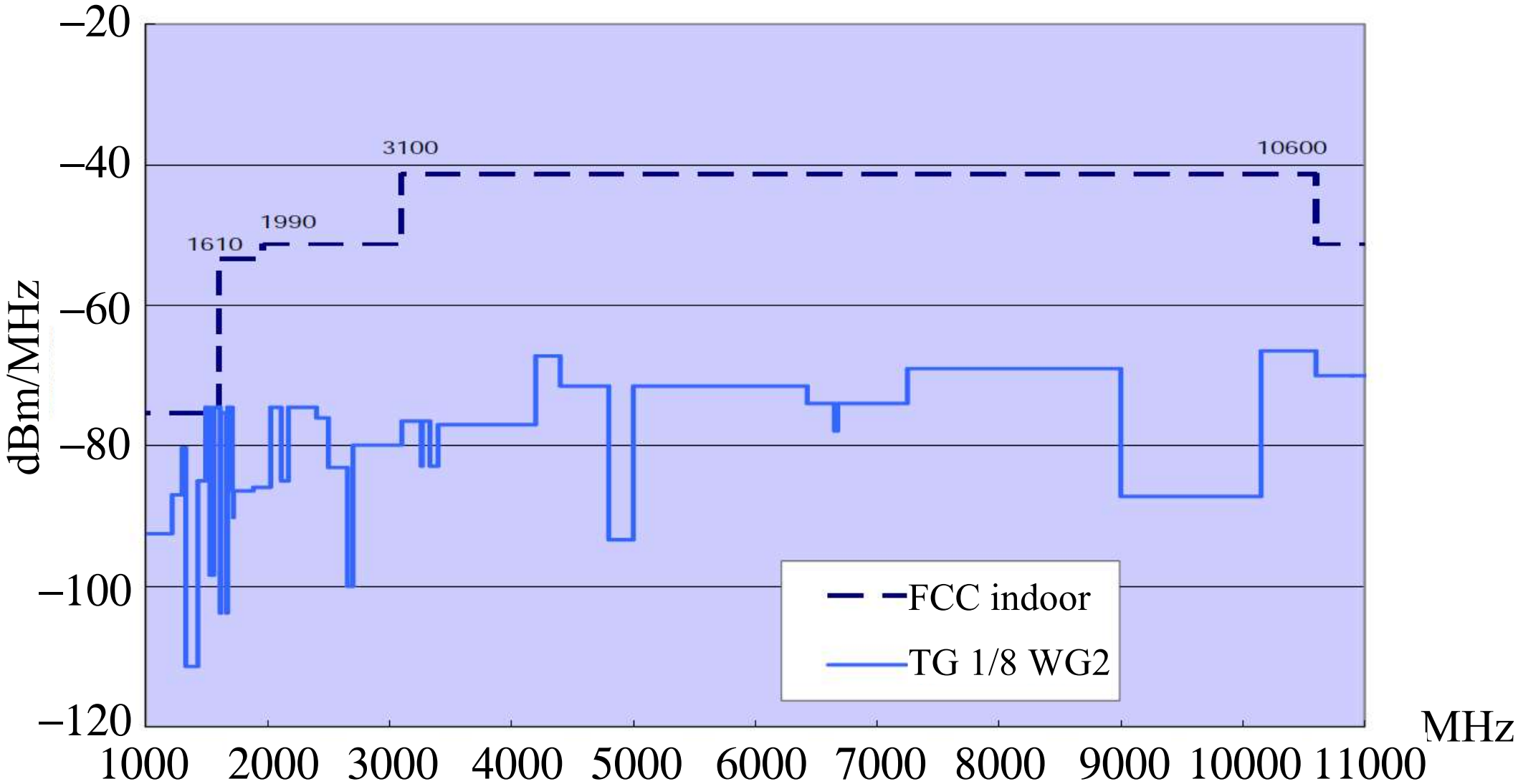

Outline

1. Background
2. Impact to existing systems and regulatory issues
3. Spectral emission mask
4. UWB parameters
5. Frequency domain vs time domain measurements
6. Measurement conditions
7. Frequency domain measurements
8. Time domain measurements

Spectral mask

- EMC-like approach
 - Same treatment as *unintended* radiation
 - Necessary bandwidth, occupied bandwidth, unwanted emissions, out-of-band domain and spurious domain do not apply to UWB.
- Upper-limit of effective isotropic radiated power spectral density
- WG1 originally in charge; now under WG 3

FCC mask for average PSD

Indoor

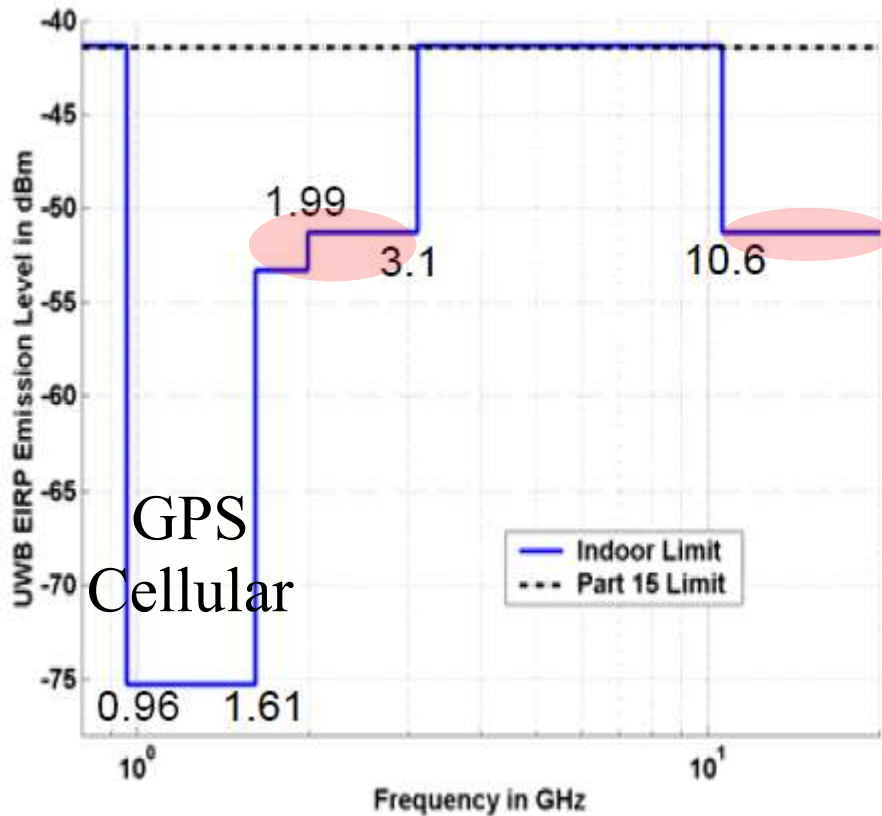

Handheld

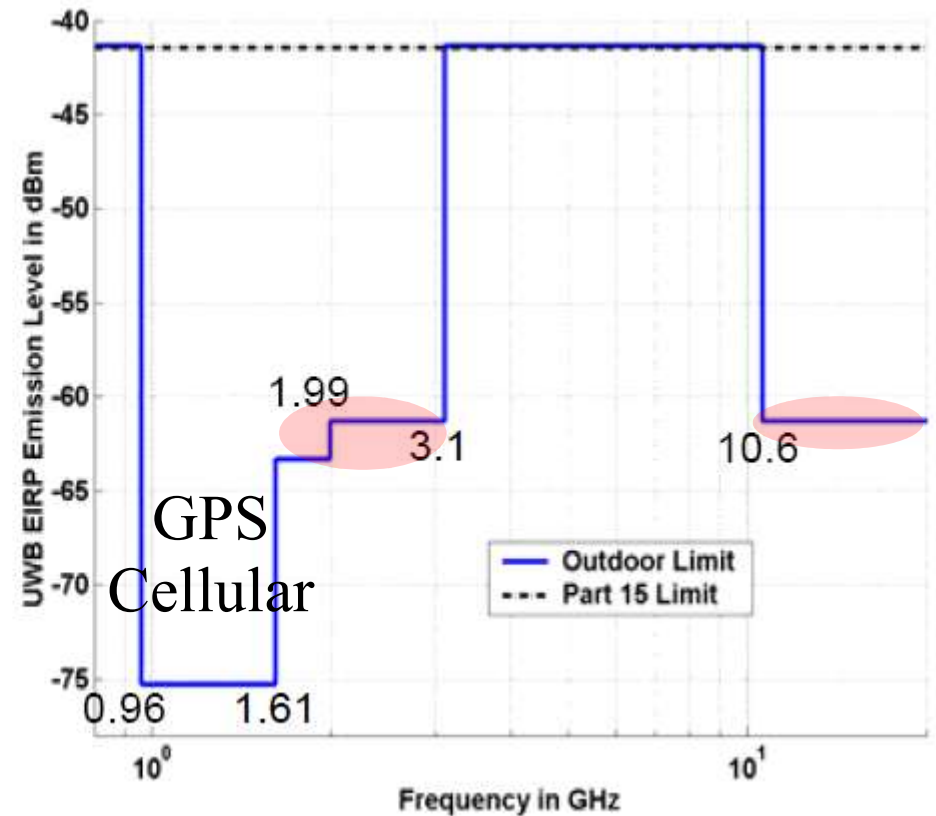

CEPT mask for average PSD

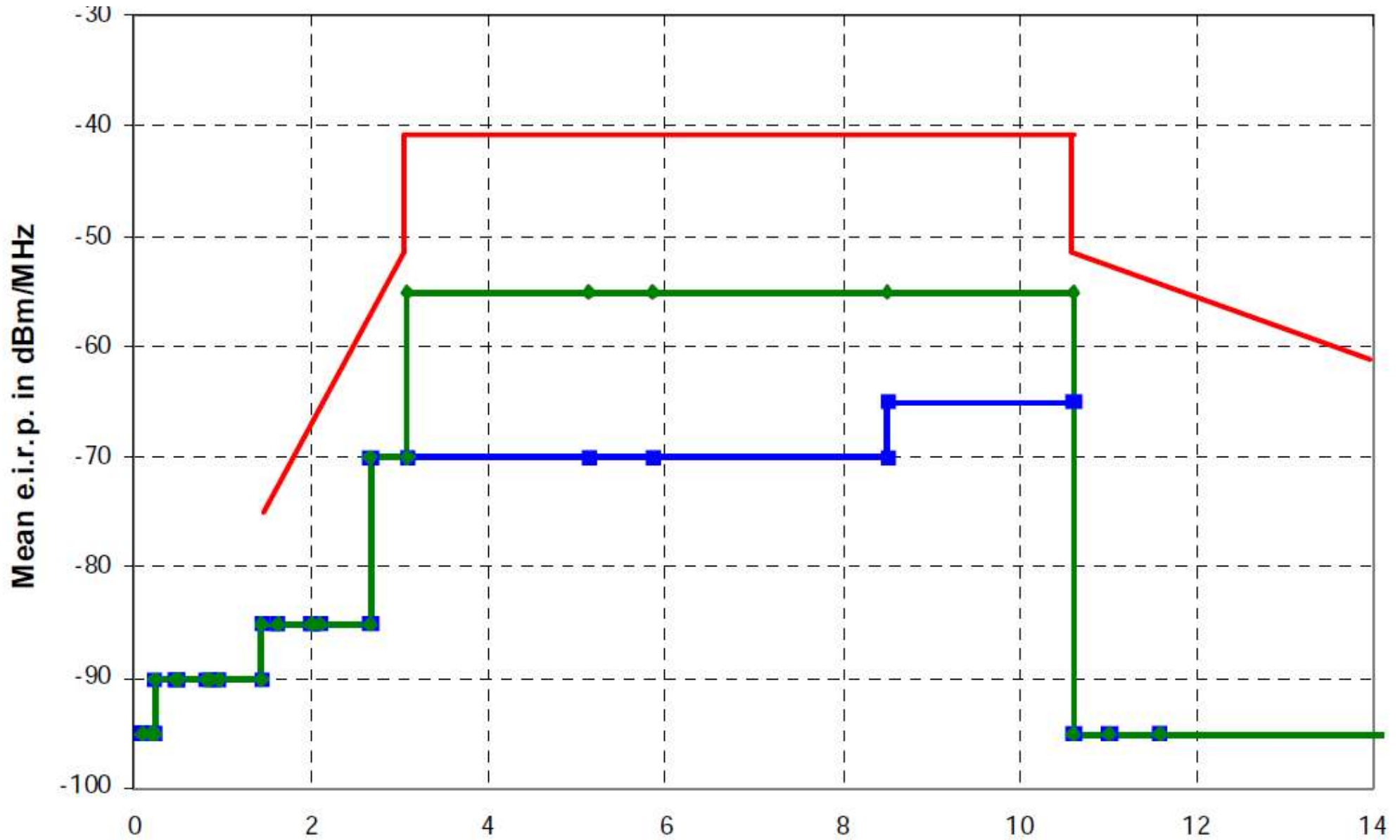

— Indoor slope mask
(obsolete)

Frequency (GHz)

Input in 5th meeting; obsolete

—■ Simplified generic mask —◆ UWB emission mask for impact analysis

Japanese mask for average PSD

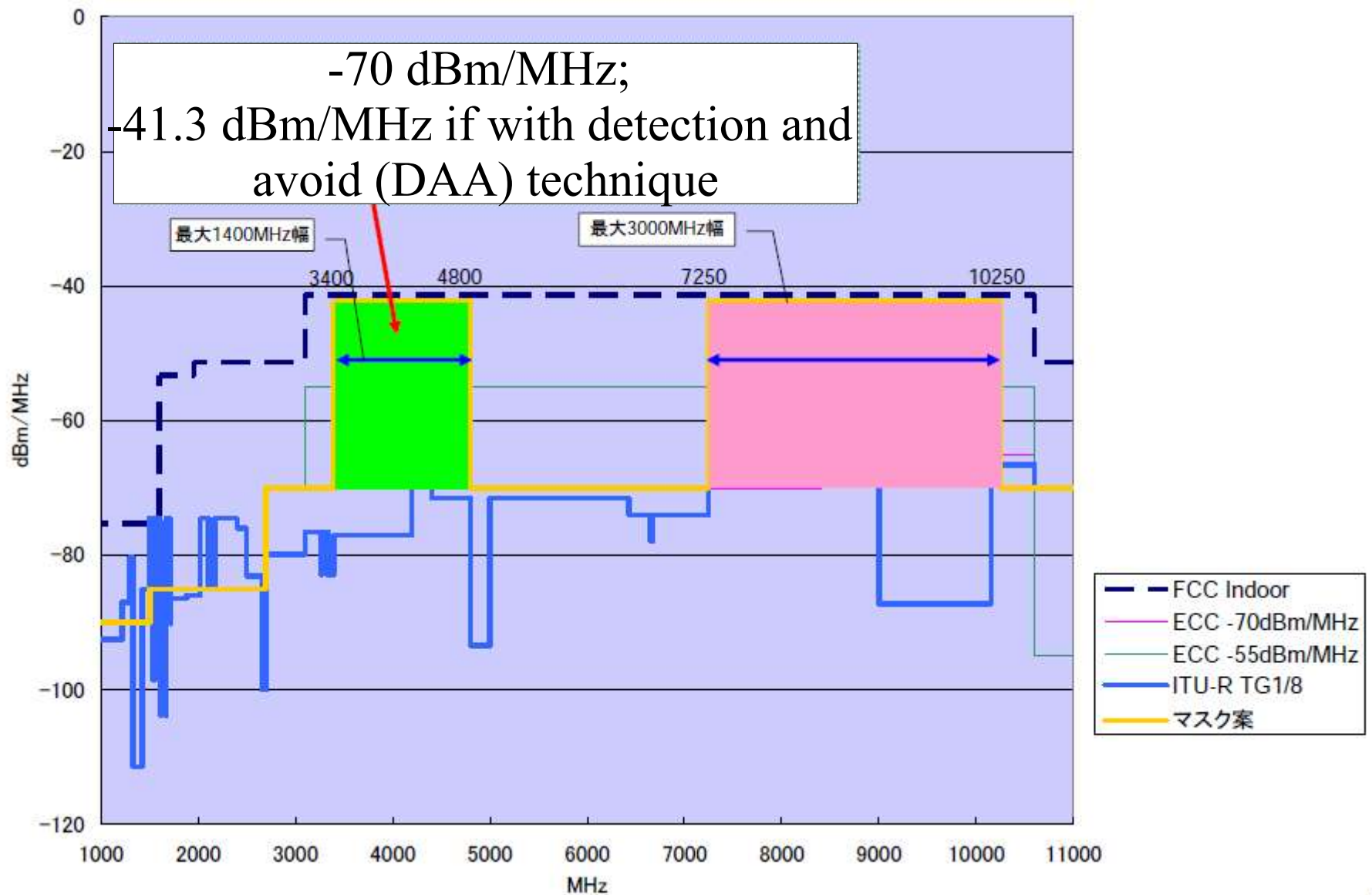

To be input to next TG 1/8 meeting

New CEPT mask for average and peak PSD

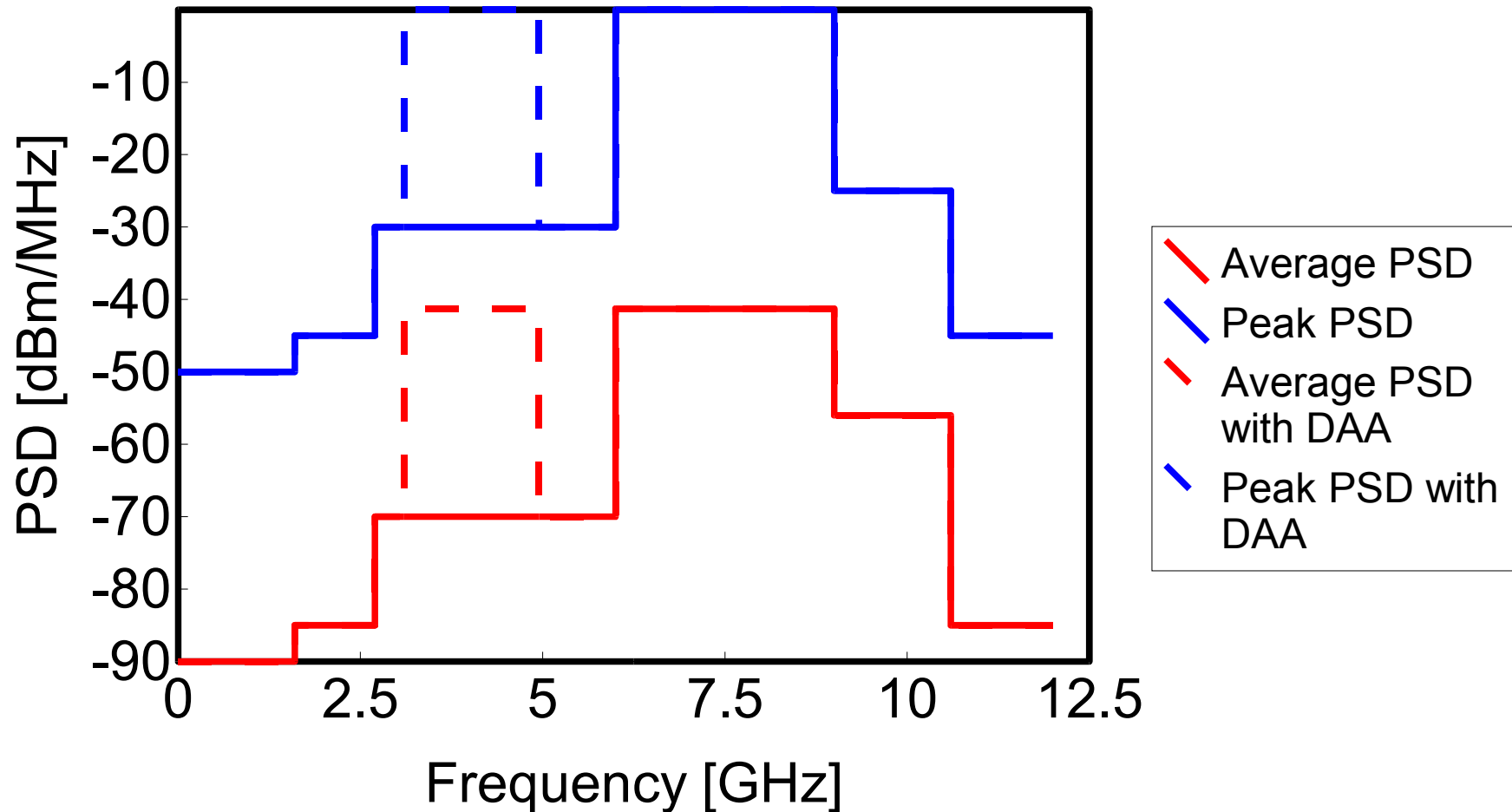

Temporarily approved in September 2005, influenced by Japanese decision

Outline

1. Background
2. Impact to existing systems and regulatory issues
3. Spectral emission mask
4. UWB parameters
5. Frequency domain vs time domain measurements
6. Measurement conditions
7. Frequency domain measurements
8. Time domain measurements

Measurement technique

- Effective isotropic radiated power (EIRP)
 - Emission measurement
- Power spectral density, not total power
 - Victim systems are band-limited.
 - Victim receivers have BPF in RF frontend.

Effective isotropic radiated power (EIRP, e.i.r.p.)

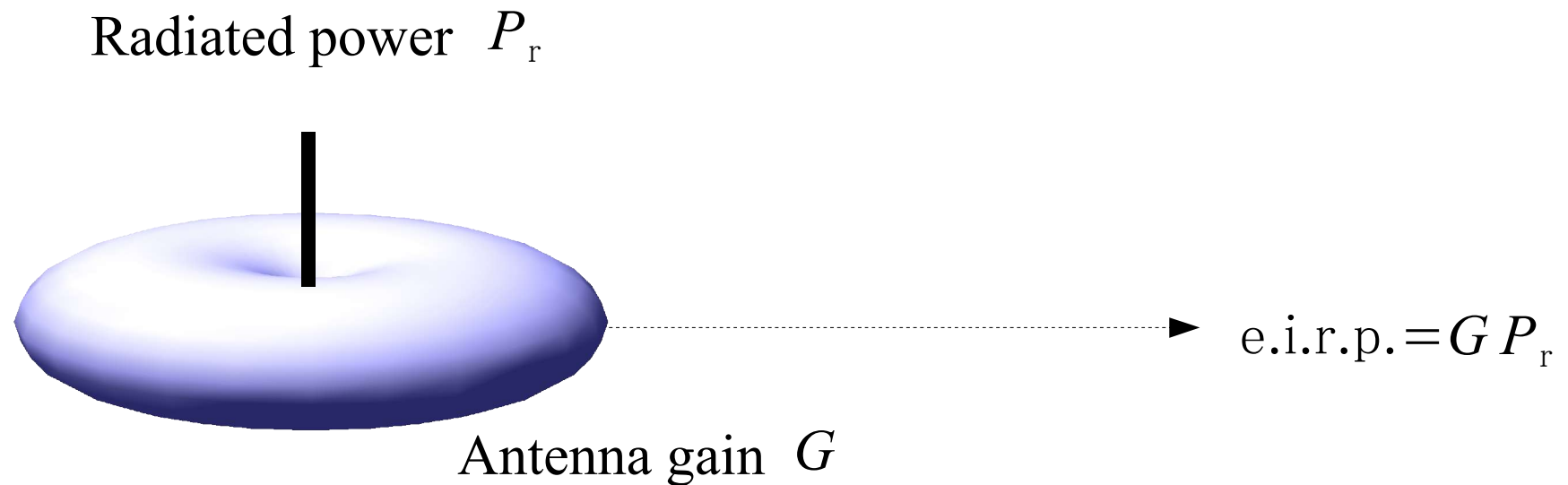

Function of angle : device is oriented to maximize the radiation.

<Not so simple as radiation pattern changes according to the frequency.>

Different detectors for EIRP (1)

Below 1 GHz

- CISPR quasi-peak detector
 - Compatibility with EMC measurements
 - Designed for compatibility with analog systems

Different detectors for EIRP (2)

Above 1 GHz : two detectors for different criteria

- Average
 - Limit of C/I for existing systems
- Peak
 - Saturation of LNA in existing receivers

Definition of UWB (1)

Defined by using UWB -10 dB bandwidth

- at least 500 MHz, or
- fractional bandwidth greater than 0.2

Definition of UWB (2)

Definition of UWB -10 dB bandwidth B_{-10}

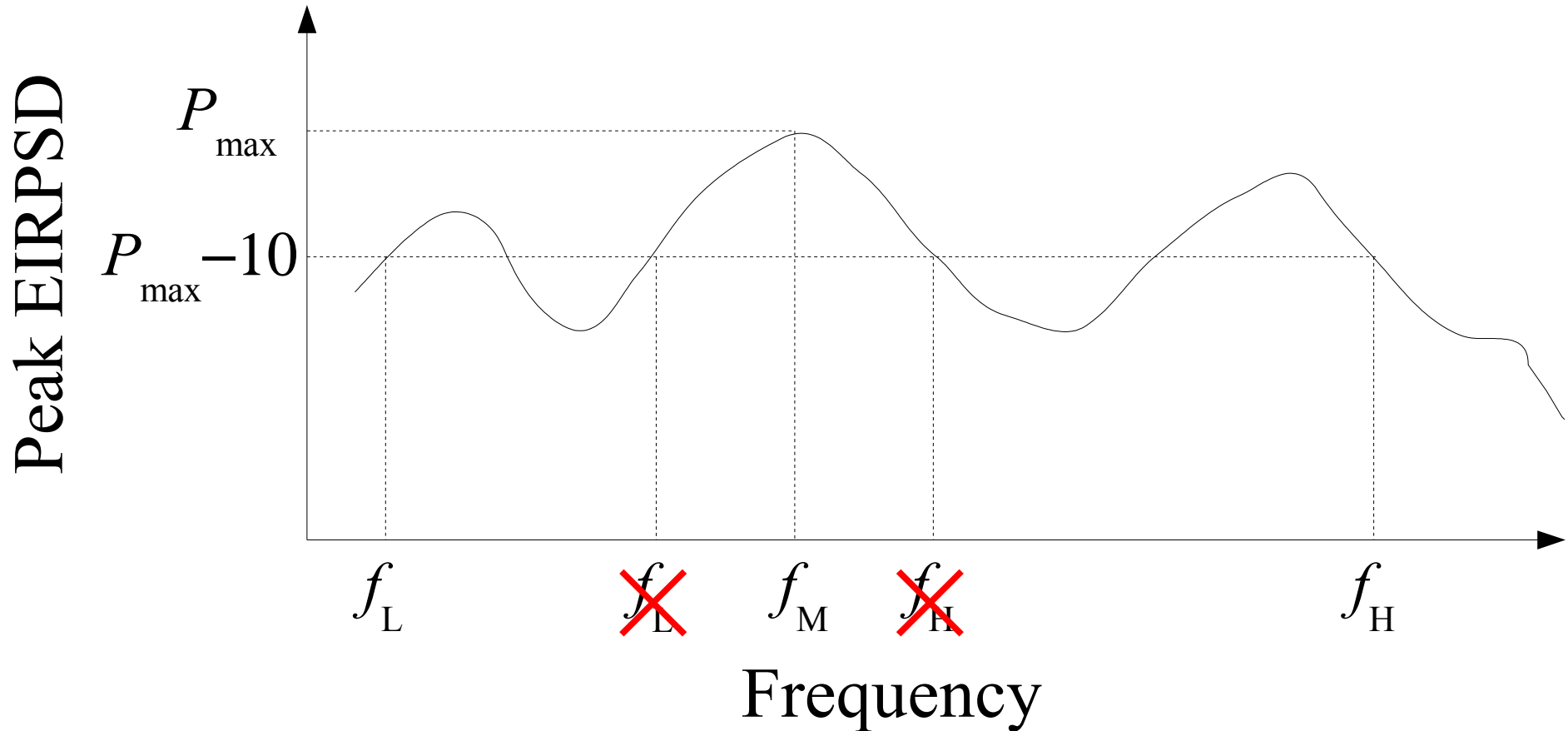

Outline

1. Background
2. Impact to existing systems and regulatory issues
3. Spectral emission mask
4. UWB parameters
5. Frequency domain vs time domain measurements
6. Measurement conditions
7. Frequency domain measurements
8. Time domain measurements

Two alternative approaches for measurement

- Frequency domain measurement
 - Spectrum analyzer
 - Standard approach
- Time domain measurement
 - Oscilloscope
 - Full band measurement suitable for peak
 - Useful for device evaluation but not suitable for regulatory measurements

Outline

1. Background
2. Impact to existing systems and regulatory issues
3. Spectral emission mask
4. UWB parameters
5. Frequency domain vs time domain measurements
6. Measurement conditions
7. Frequency domain measurements
8. Time domain measurements

Test site

- Radiation measurement
- 3 m separation
 - Anechoic chamber
 - Semi-anechoic chamber (below 1,000 MHz only)
 - Open area test site <not so quiet in reality>
- Detection of peak radiation by rotating DUT
<Peak direction is frequency dependent.>

Radiation measurement

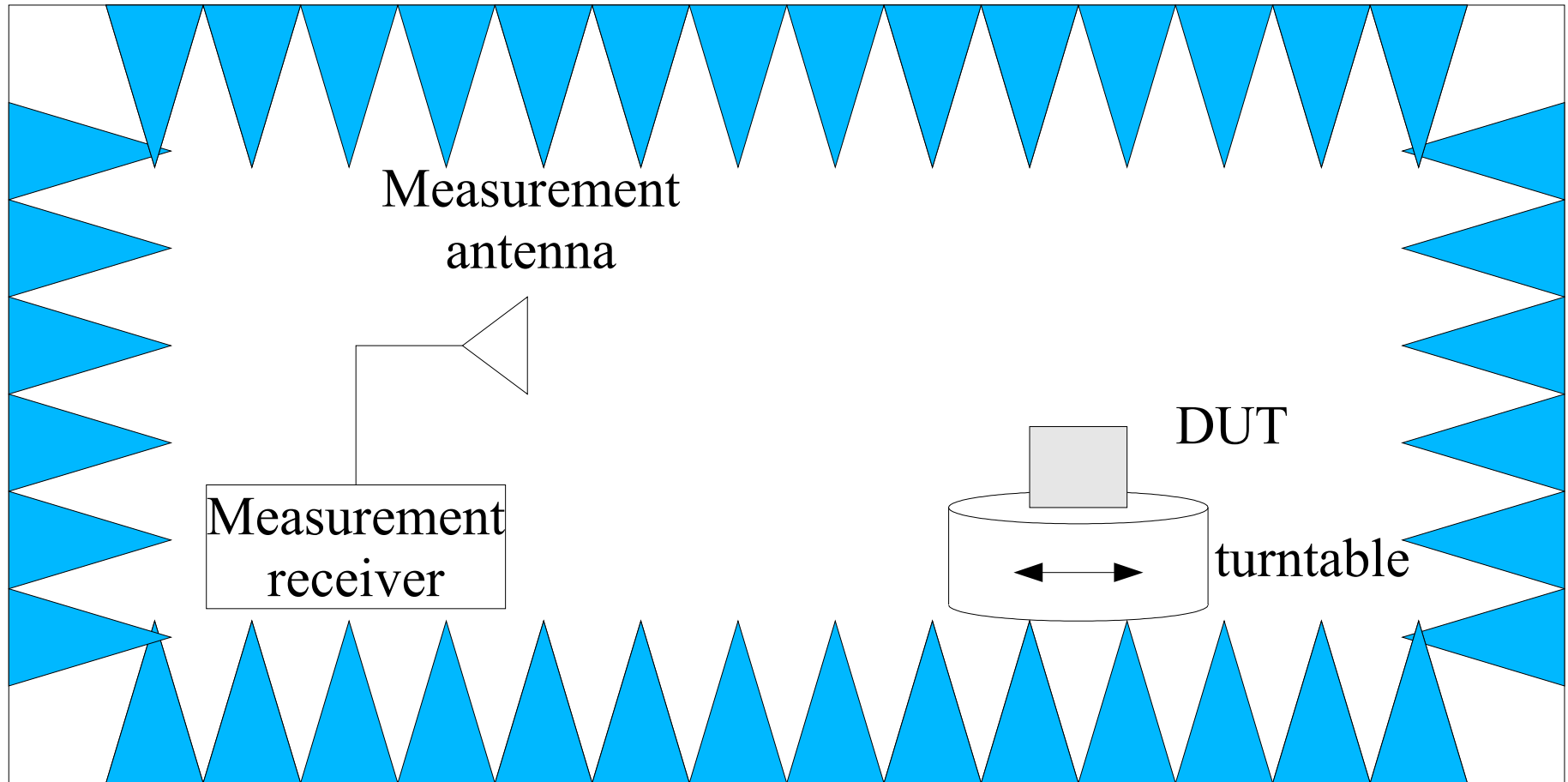

Angular sample points

- Number of ripples in 360 degrees

$$N \simeq \frac{2\pi f r_0}{c}$$

Radius of sphere
enclosing DUT

– 5 to 10 samples for one ripple (rule of thumb)

– Example:

A4 size laptop PC operating up to 6 GHz

→ $N = 25 \sim$ every 1.5 to 3 degree for sampling

Outline

1. Background
2. Impact to existing systems and regulatory issues
3. Spectral emission mask
4. UWB parameters
5. Frequency domain vs time domain measurements
6. Measurement conditions
7. Frequency domain measurements
8. Time domain measurements

Spectrum analyzer

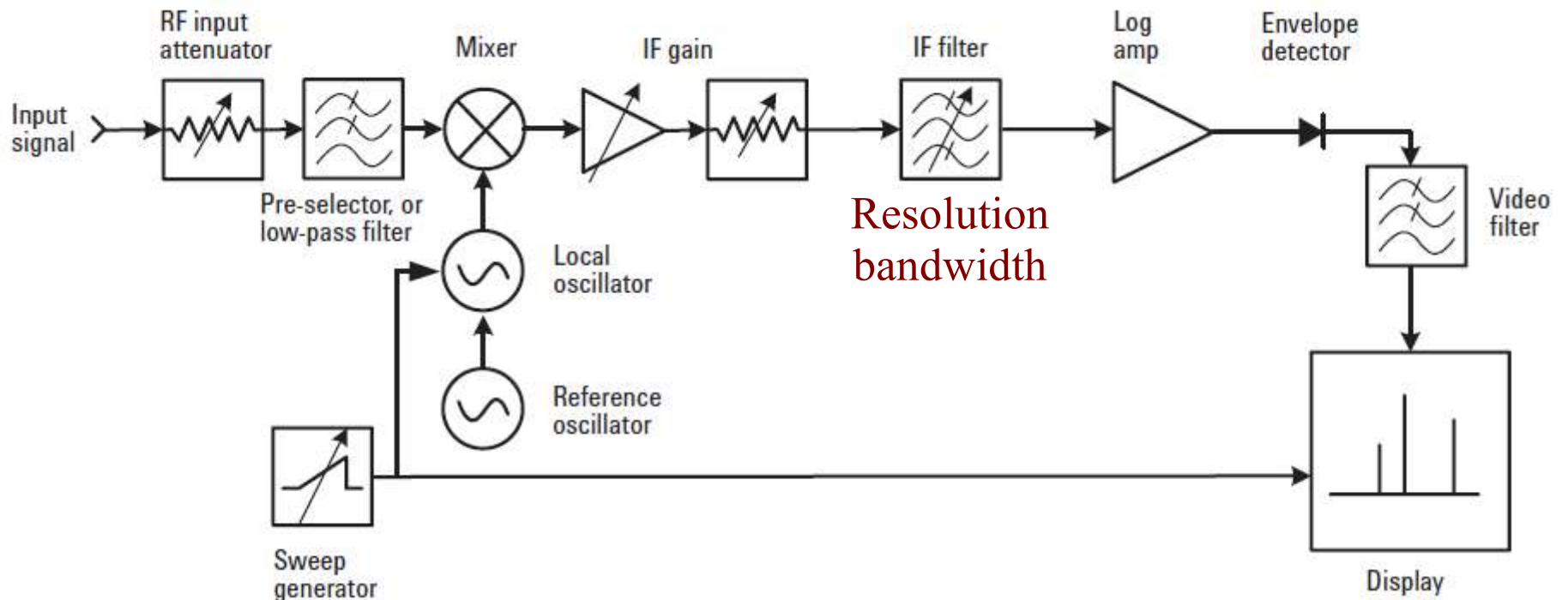

Spectrum analyzer characteristics

- Super heterodyne architecture
- Sweep frequency local oscillator (LO)
 - Sample timing for each frequency bin is different.
- Results influenced by
 - Sweep time
 - Measurement time window
 - Duty ratio
 - Pulse repetition frequency
- Low sensitivity – high NF

State-of-art digital-IF spectrum analyzer

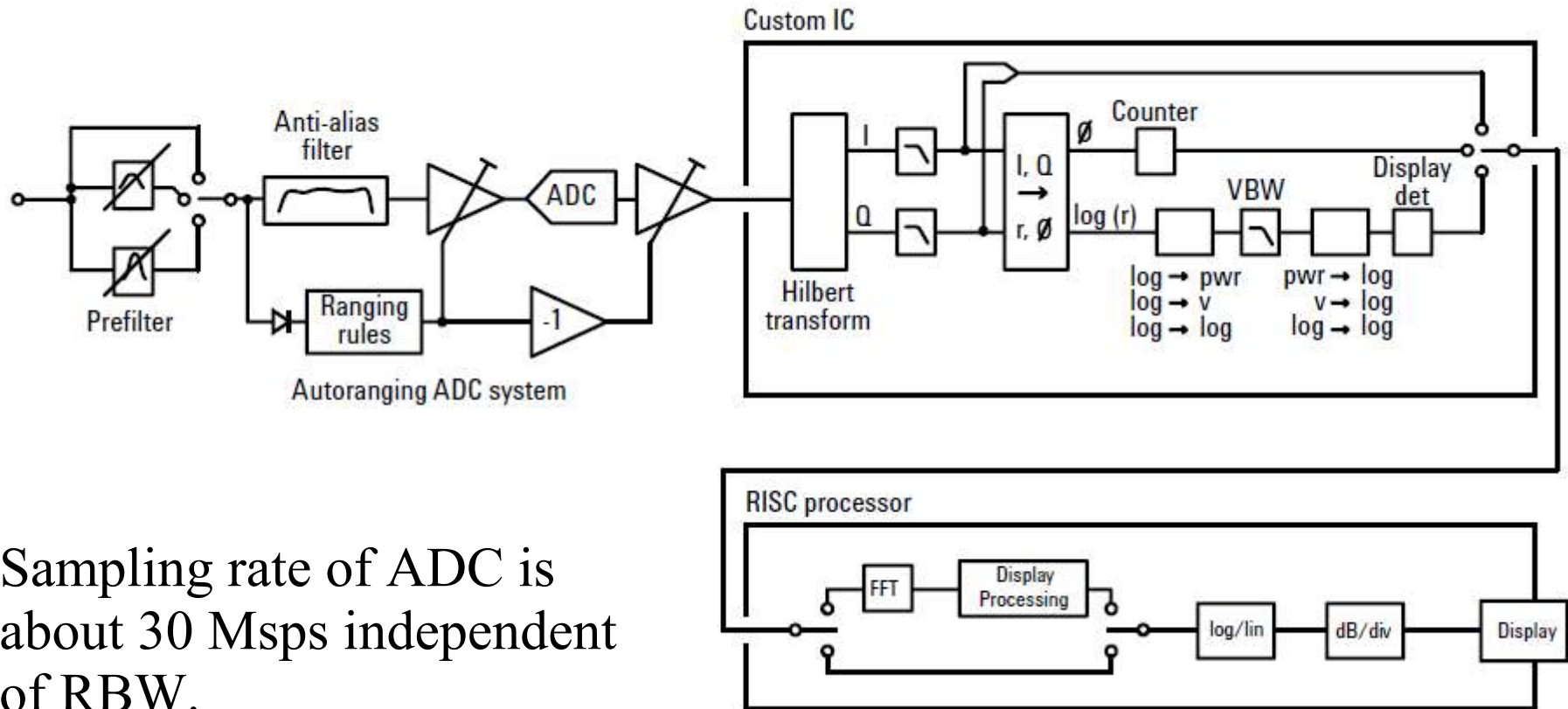

Sampling rate of ADC is about 30 Msps independent of RBW.

Quasi-peak (QP) measurement

- Below 1,000 MHz
- CISPR-16 QP detector <for EMC>
 - Time constant of detector is 550 ms
<time consuming>
- Peak detector for preliminary test
 - $peak PSD > QP PSD$

Average measurement

- 1MHz resolution bandwidth (RBW)
Gaussian filter with 3 dB bandwidth
- RMS average value
- Averaging time below 1 ms

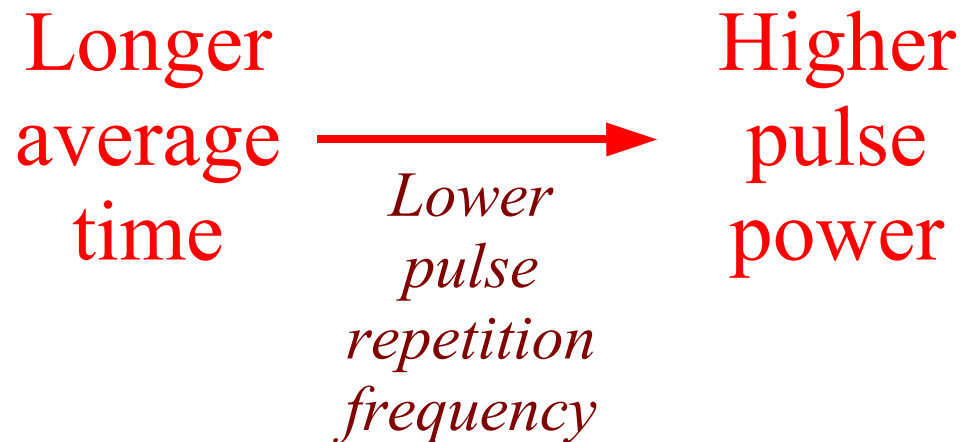

Average measurement: example

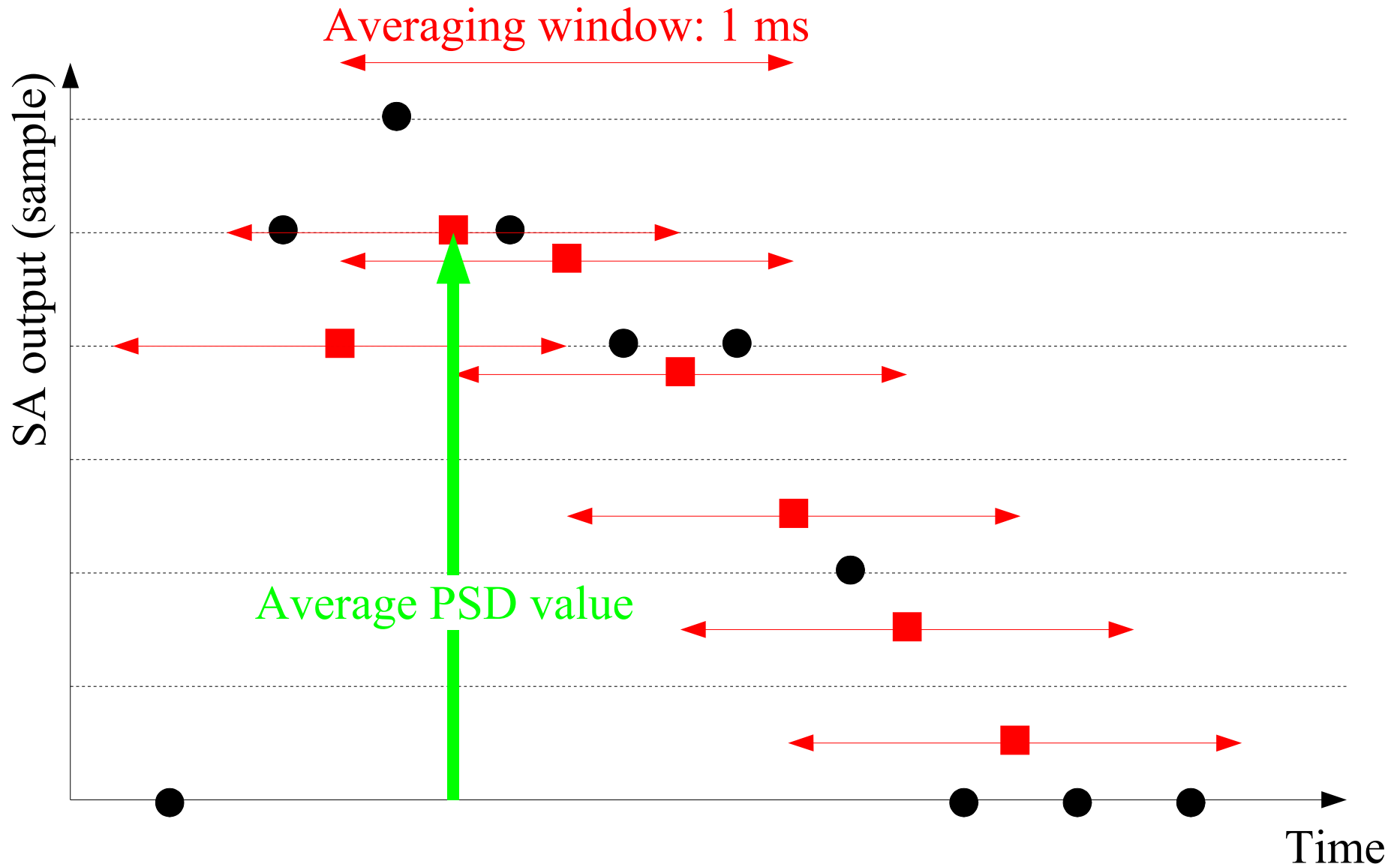

Peak measurement (1)

- Peak power is defined for 50 MHz bandwidth.

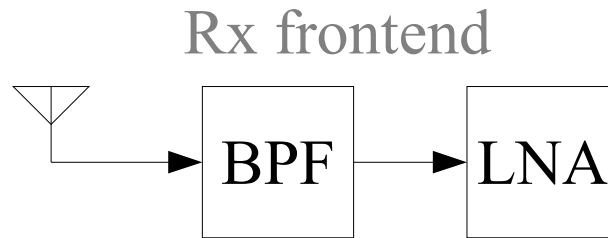

Received signal is not directly input to LNA but to BPF.
BW of BPF is 50 MHz at maximum.

- Frequency with maximum radiation f_M is used.
<only for critical frequency>

Peak measurement (2)

- 1 MHz \downarrow RBW \downarrow 50 MHz for measurement

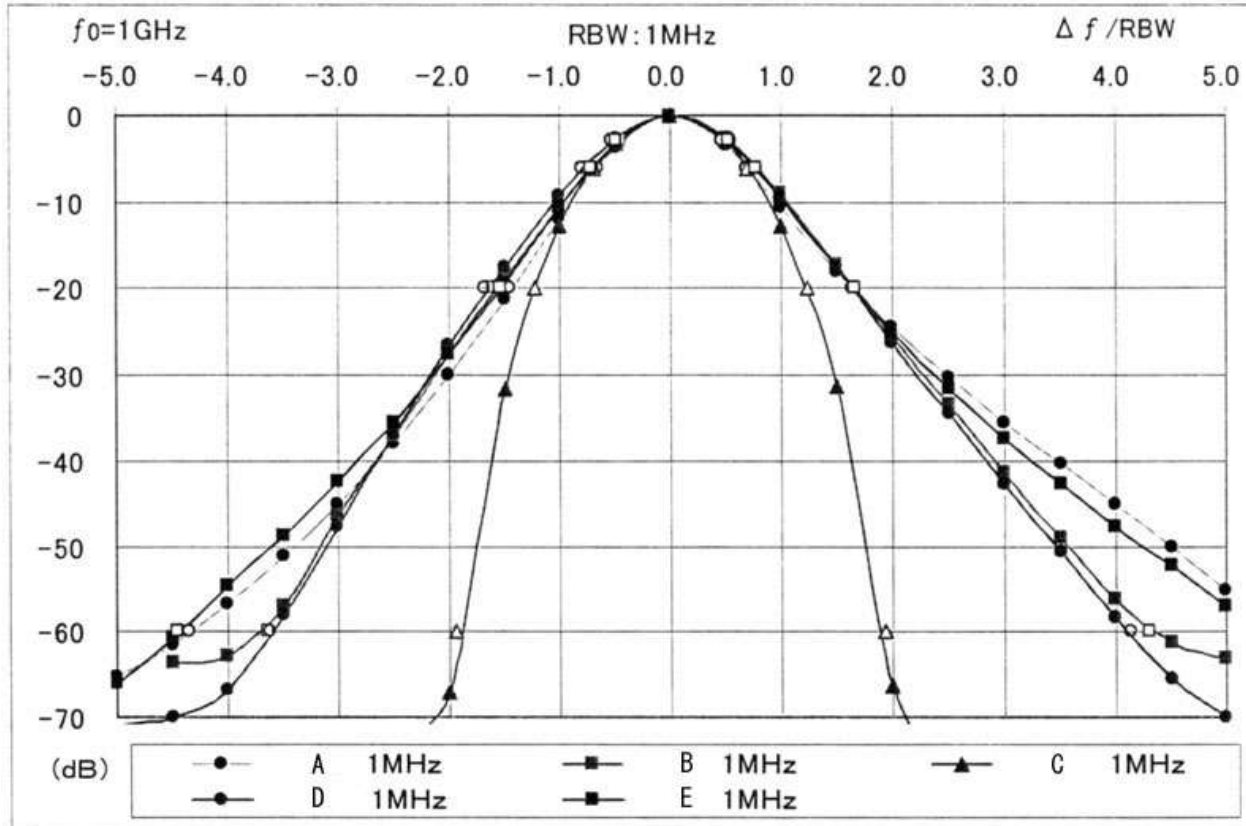

For wider RBW:

- Non-Gaussian
- Phase distortion



Optimistic result

Peak measurement: example

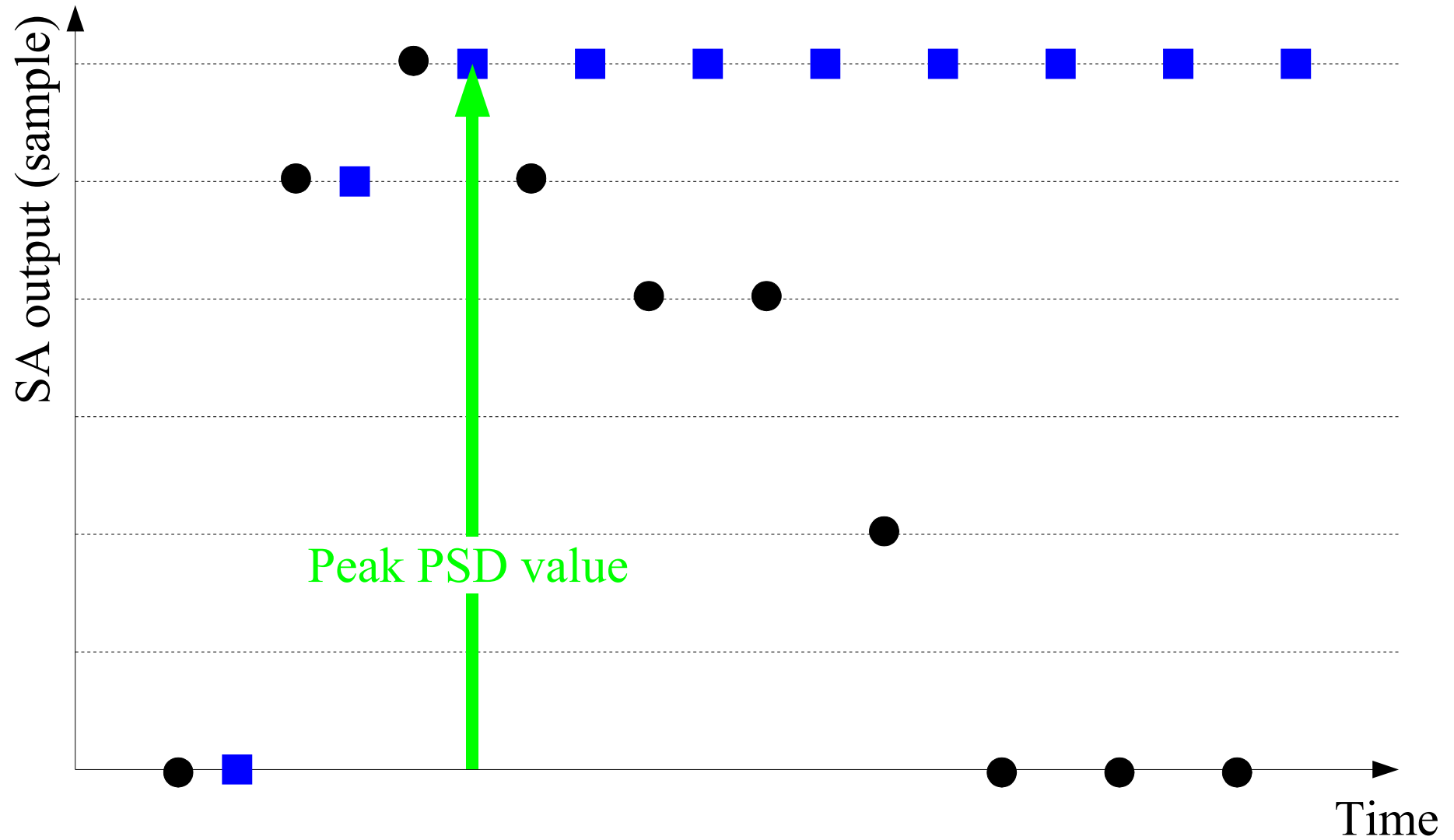

Peak measurement (3)

- $20\log(\text{RBW}/50)$ [dB] <voltage sum law> is added for scaling.

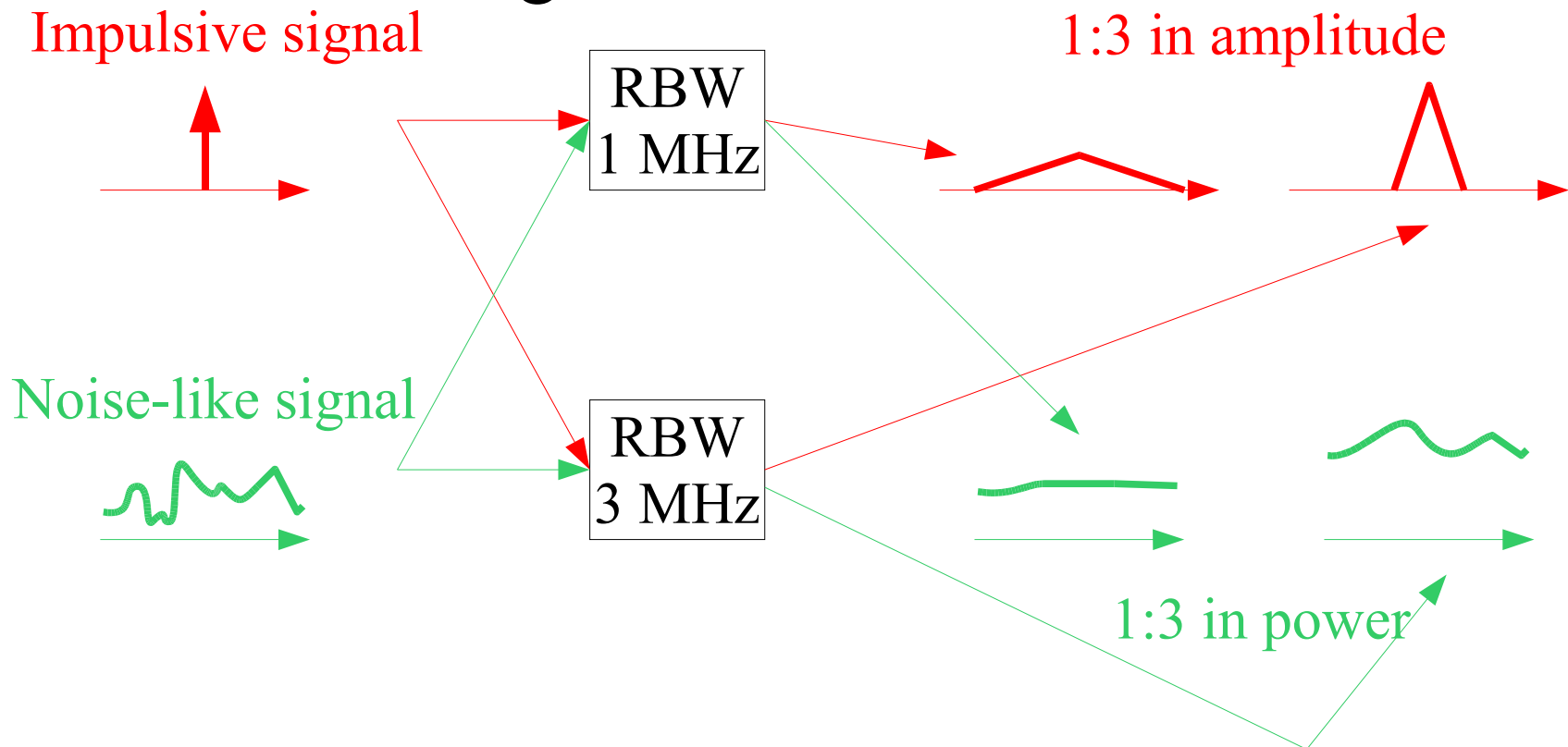

Appropriate for impulse; conservative for noise-like signal.

Choice of video filter

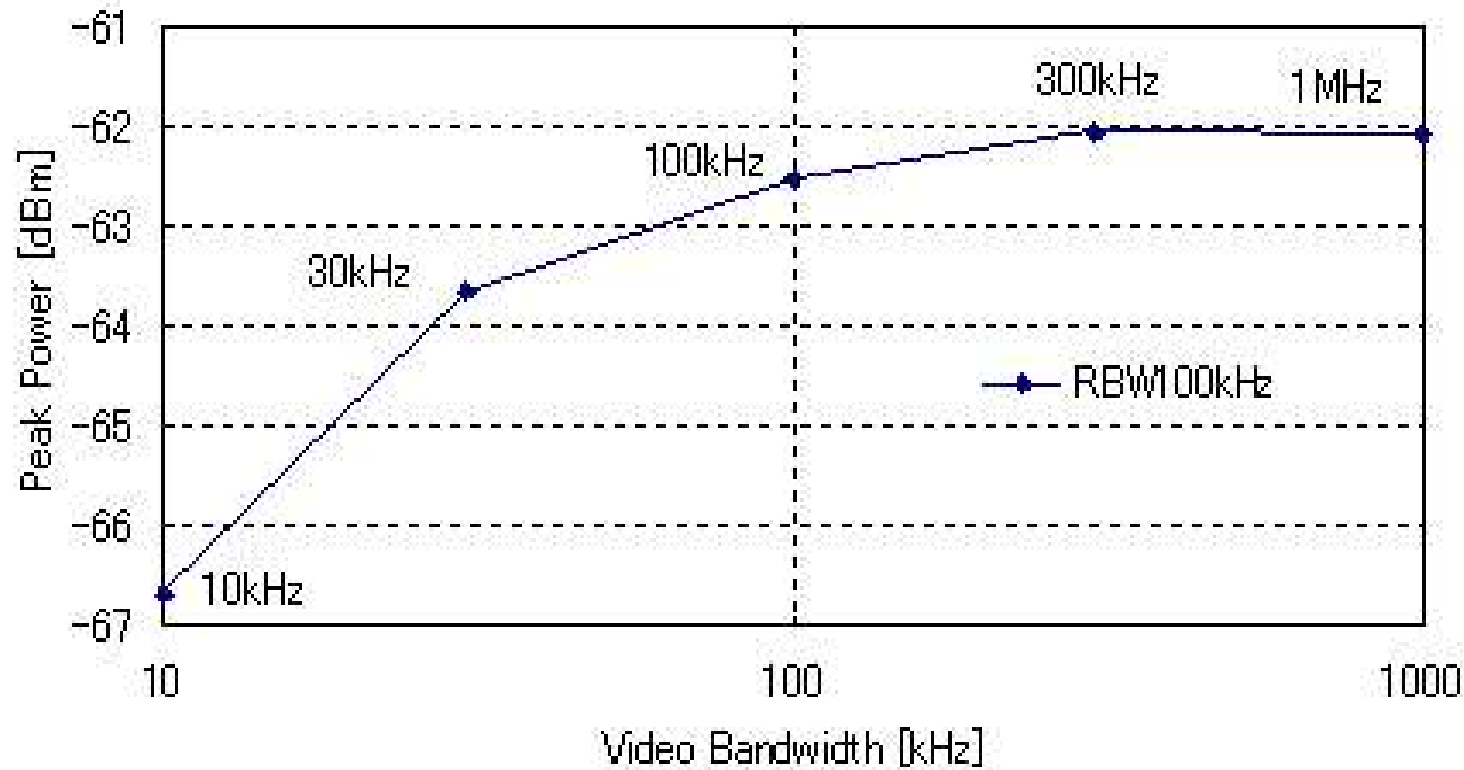

VBW \geq 3 \times RBW or just bypass

Measurement in reverberation chamber

Randomization of internal EM field

- Same mechanism as multipath fading

Substitution method

- Comparison with standard source.

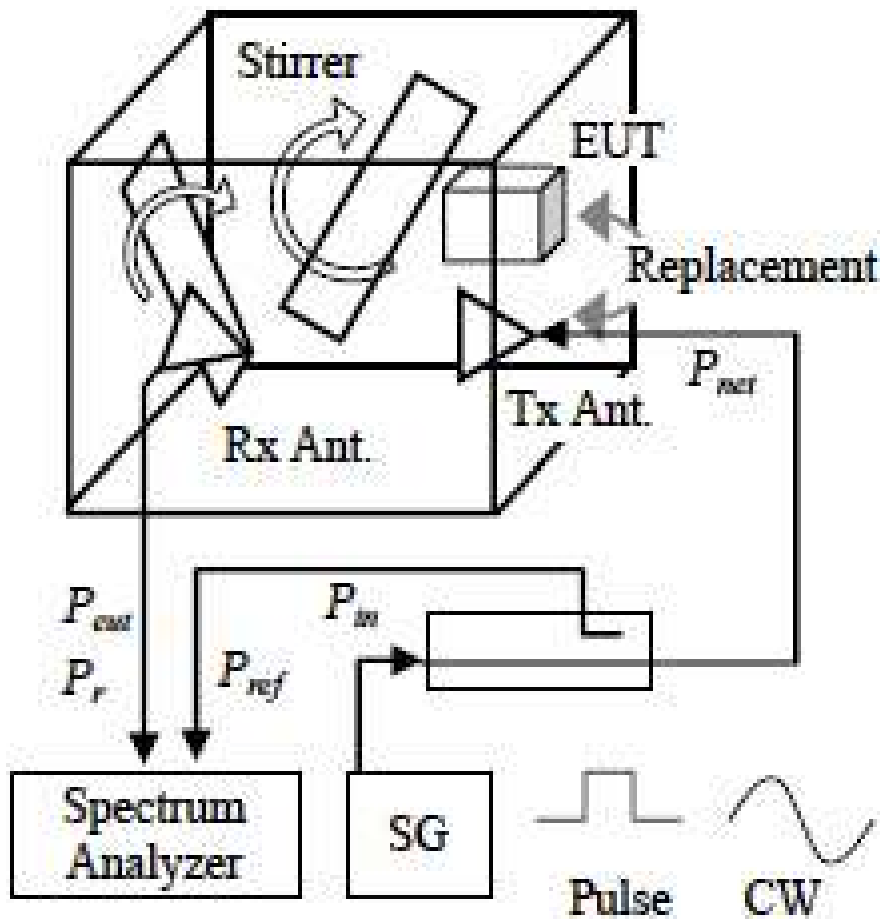

Used to find f_M and rough spectrum

Noise EIRP of spectrum analyzer (1)

- Noise power of the receiver

$$N [\text{dB/Hz}] = 10 \log_{10} kTB + F$$

$k = 1.38 \times 10^{-23}$ J/K : Boltzmann's constant

T K : temperature of receiver <290 K>

B Hz : receiver noise bandwidth

F dB : noise figure

Noise EIRP of spectrum analyzer (2)

- Noise power of Rx for 1 MHz bandwidth

$$N \text{ [dBm/MHz]} = -114 + F$$

- $F = 18\text{--}24$ dB for SA

Noise EIRP of spectrum analyzer (3)

- Friis' transmission formula

- Relation between EIRP P_{te} and Rx power P_r

$$P_r = P_{te} + 20 \log_{10} \lambda - 20 \log_{10} (4\pi d) + G_r$$

- λ m: wavelength <2.5 – 10 cm>

- d m: distance between DUT and Rx antenna <3 m>

- G_r dB: Rx antenna gain <2–4 dBi>

- Equivalent noise EIRP

- –50 to –60 dBm/MHz

Low level emission measurement

- It is impossible to measure EIRP at 3 m from DUT due to noise.
 - Minimum measurement range is -40 to -50 dBm/MHz EIRP with 10 dB SNR.
- Scaling law of 20dB/decade is used assuming far field condition.
 - Usually conservative in near field region.
- LNA shall be used.

Radiometric measurement for very low level emission

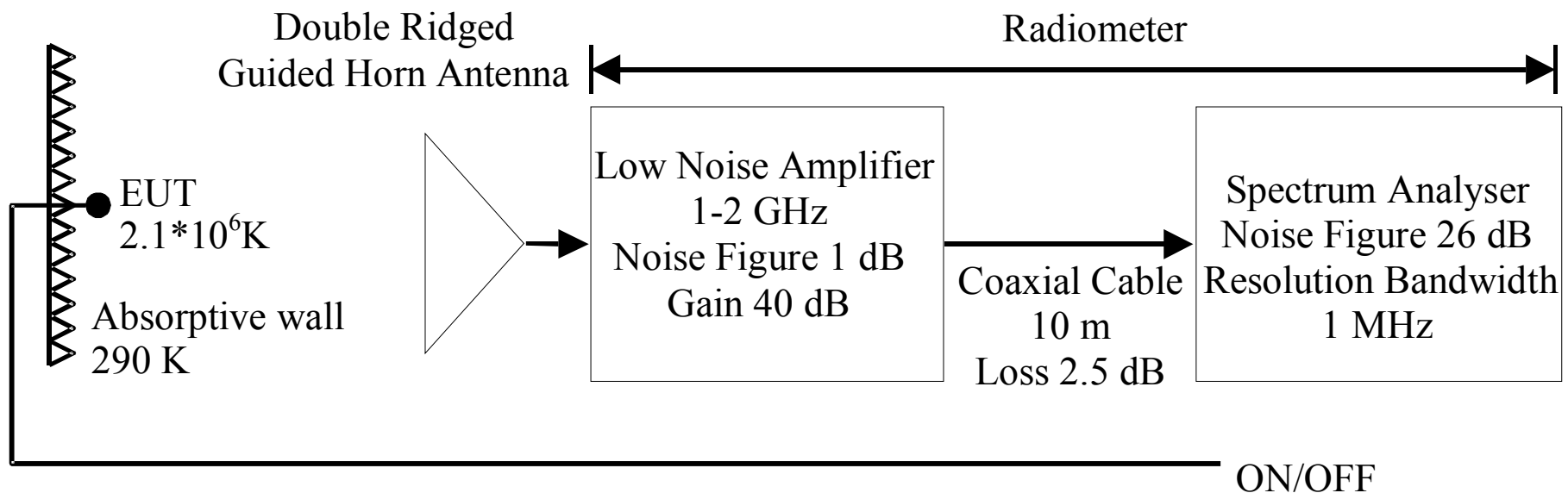

Radiometry

- Measurement of background + DUT emission
- Subtraction of background noise
- Same approach as radio astronomy

Conducted measurement (1)

Direct connection between SA and antenna port



$$\text{EIRP} = \text{TRP} + \text{antenna gain}$$

Conducted measurement (2)

- Pros

- No test site needed
- No rotation of DUT needed <drastic time saving>

- Cons

- Impedance matching may not be achieved.
<Difference of matching conditions result in error.>
- Not applicable for antenna-integrated devices
- Antenna characteristics to be separately known for conversion to EIRP

Outline

1. Background
2. Impact to existing systems and regulatory issues
3. Spectral emission mask
4. UWB parameters
5. Frequency domain vs time domain measurements
6. Measurement conditions
7. Frequency domain measurements
8. Time domain measurements

Time domain measurement

State-of-art oscilloscopes

- Single-event oscilloscope
 - 12 GHz
 - 8-bit ADC
- Sampling oscilloscope
 - 50 GHz
 - 14-bit ADC

Dynamic range of time domain measurement

- Dynamic range D dB for n bit ADC

$$D = 20 \log_{10} 2^n$$

– Example

To measure an UWB signal with $D = 60$ dB,
at least 10 bits quantization is required .

- Noise floor of analog front end

Jitter in sampling oscilloscope

- Sampling jitter
 - PDF: $h(\tau)$
- Measured waveform

$$s'(t) = \int_{-\infty}^{\infty} s(t - \tau) h(\tau) d\tau$$

$h(\tau)$ behaves like impulse response of LPF

<optimistic results>

Time domain measurement

- Pros
 - Arbitrary processing, i.e. wideband filtering, peak detection, CCDF, etc., is possible offline.
- Cons
 - Limited dynamic range
<not suitable for low level mask>

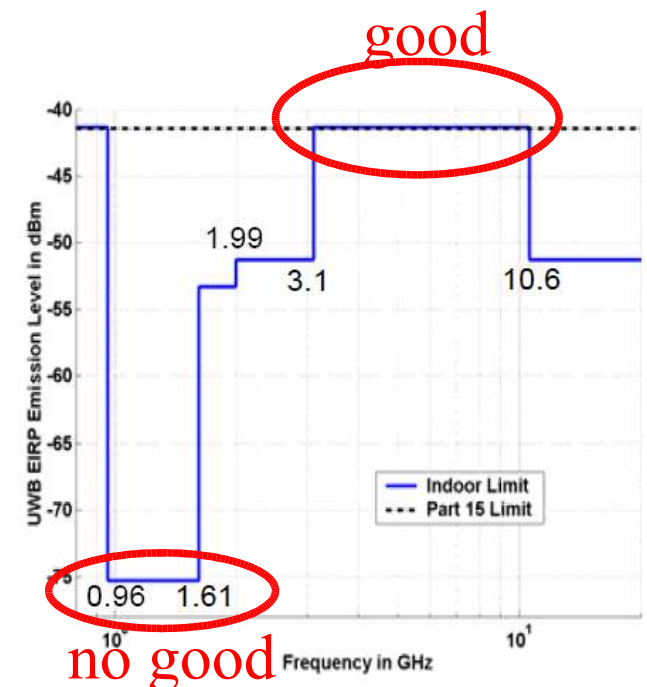

Peak power measurement in time domain (1)

Measurement system

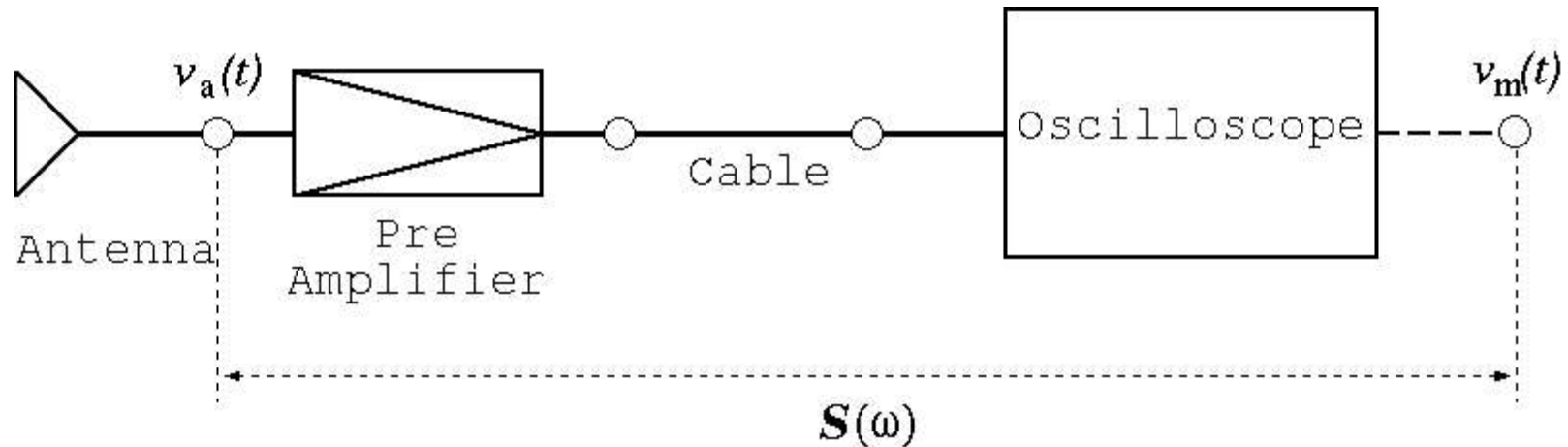

Complex antenna factor (CAF):

Conversion from antenna output voltage to incident electric field

Peak power measurement in time domain (2)

Flow of signal processing

oscilloscope

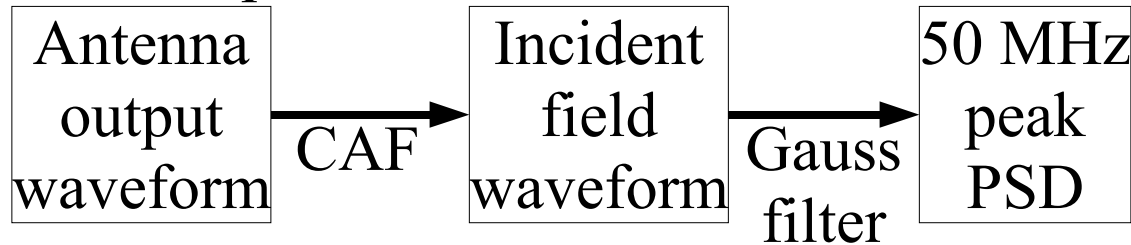

Offline processing

Time domain measurement : example

System

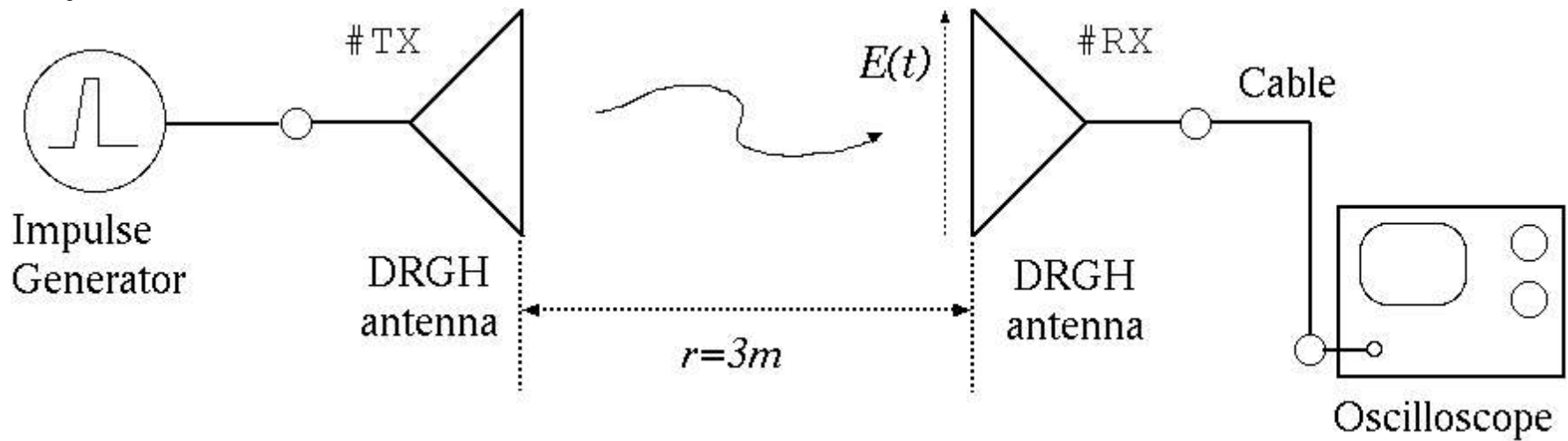

Antenna
output
voltage

CAF

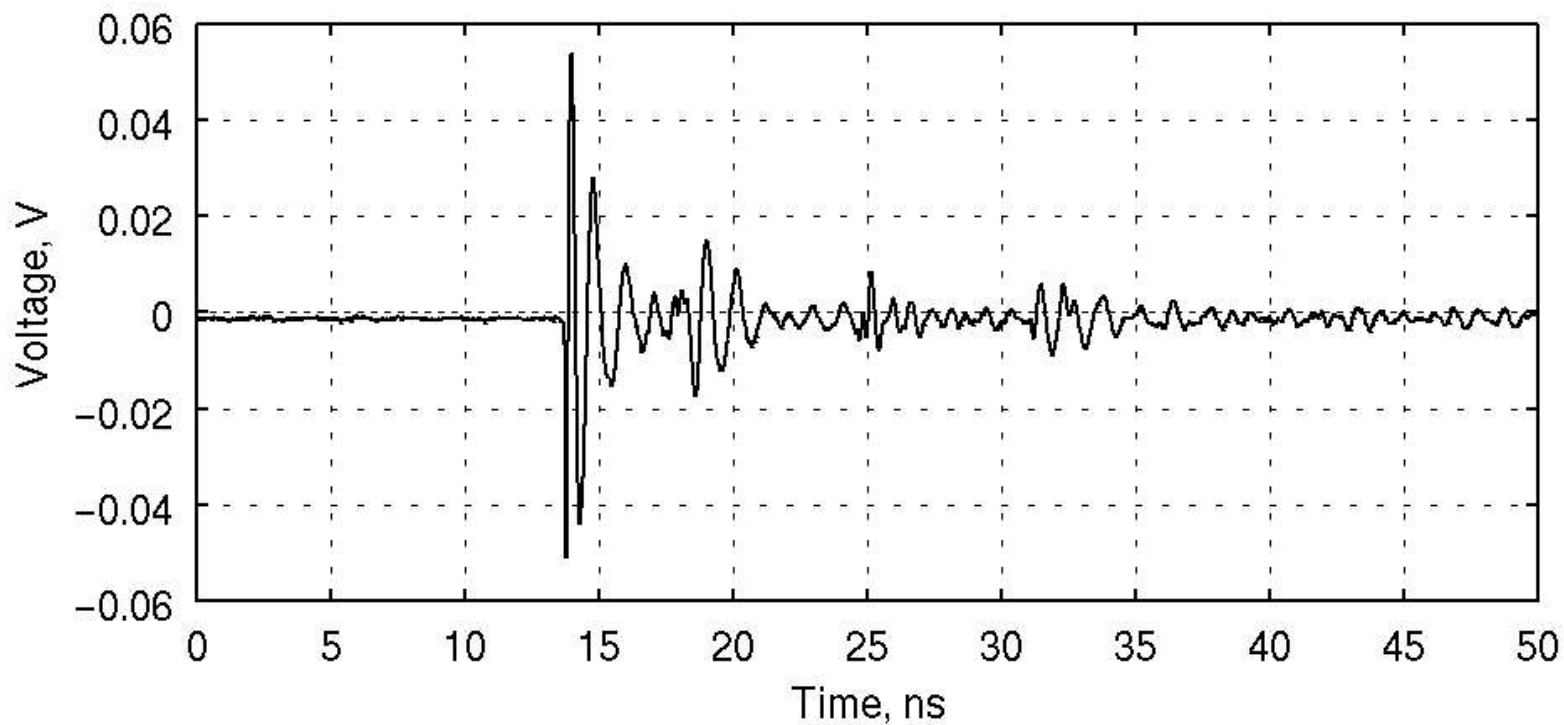

Incident
electric
field

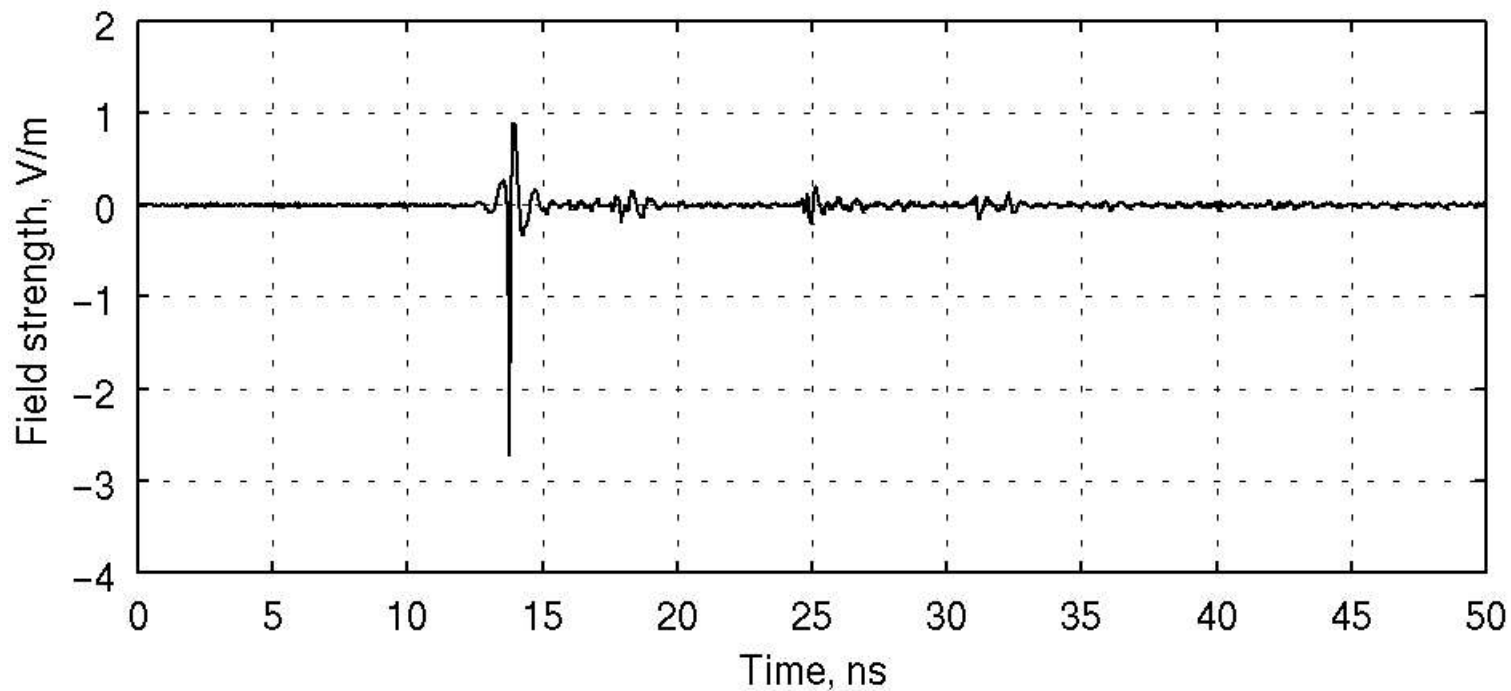

Incident
electric
field

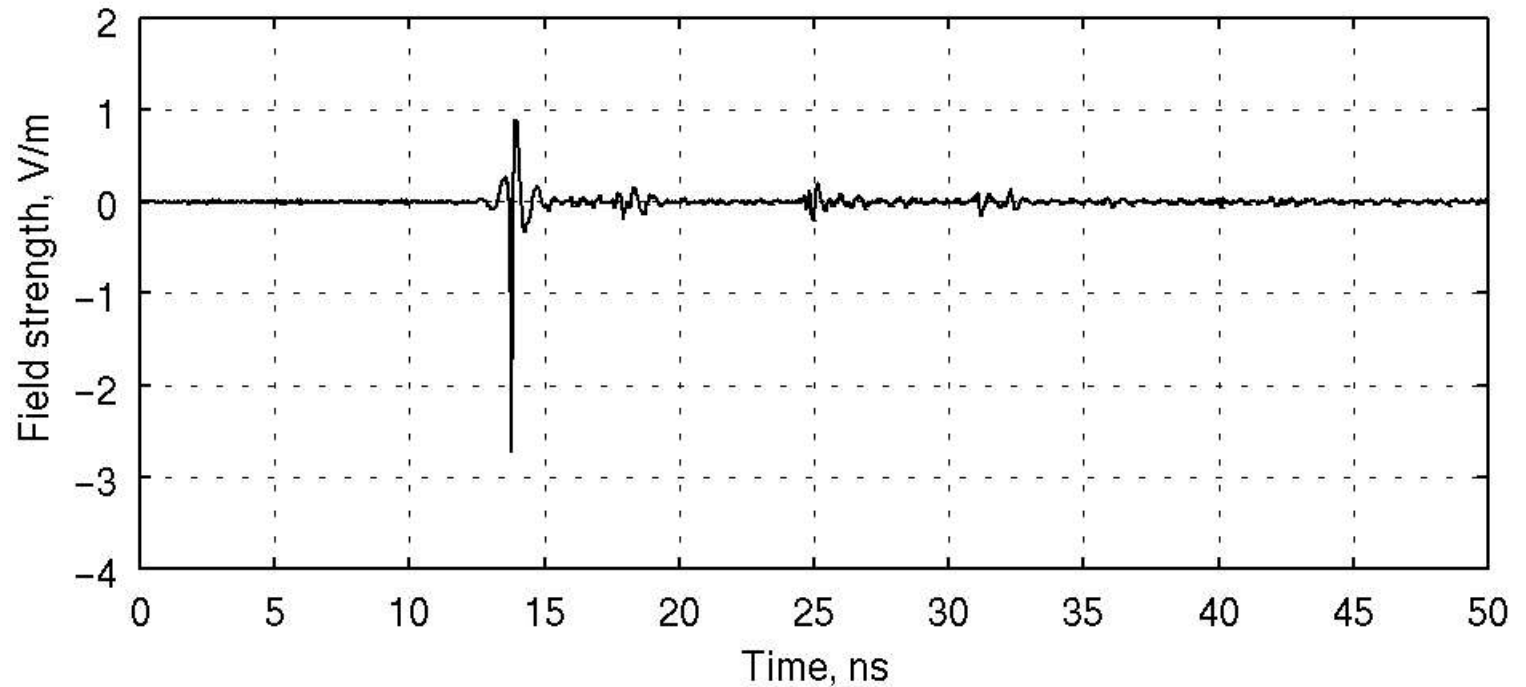

50 MHz
Gaussian
filtering

Filtered
output

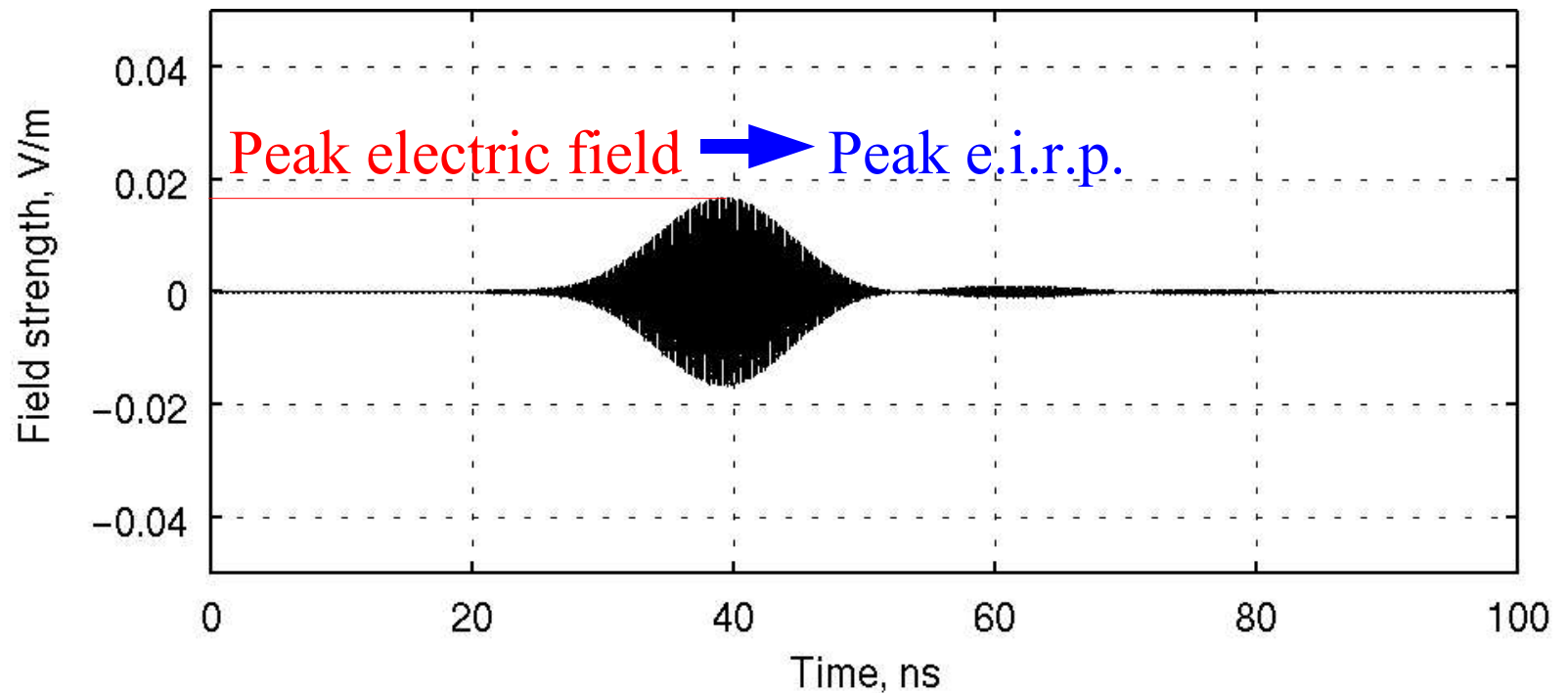

Peak power for 50 MHz bandwidth is correctly obtained.

Summary

- Standard techniques of the emission measurements of the UWB devices discussed in ITU-R TG 1/8.
 - Draft new recommendation will be finalized in the last meeting in Oct. 2005.
- Challenges
 - Measurement at very low power level
 - Efficient peak detection in angle, frequency, and time domains

Status of ITU-R TG 1/8

- WG1: UWB characteristics
 - Still discussing about the top level definition of terms; incompatibility with ITU-R terminology
- WG2: impact to existing services
 - Standoff between proponents and opponents
 - Large amount of data; not well organized yet
- WG3: frequency management framework
 - Almost completed
- WG4: measurement techniques
 - Almost completed

References

- Chairman, Task Group 1/8, “REPORT ON THE FIFTH MEETING OF ITU-R TASK GROUP 1/8,” ITU-R Document 1-8/347-E, 17 June 2005 (with Annexes 1-5).
- Jun-ichi Takada, Shinobu Ishigami, Juichi Nakada, Eishin Nakagawa, Masaharu Uchino, and Tetsuya Yasui, “Measurement Techniques of Emissions from Ultra-Wideband Devices,” IEICE Transactions on Fundamentals, vol. E88-A, no. 9, pp. 2252-2263, Sept. 2005.